

## P-BRIDGED CALIXARENE PHOSPHATES

© Jörg Gloede

WITEGA, Angewandte Werkstoff-Forschung, gGmbH, Justus-von-Liebig-Str., 3; D-12489 Berlin, Germany.  
E-mail: gloede@witega.de

**Keywords:** aromatic phosphates, calixarene phosphates, synthesis, phosphorus pentachloride, phosphorus oxychloride.

### Results and Discussion

The synthesis of calixarene phosphates [1] was present in three parts.

#### I. Aromatic Phosphates or the Reaction of Phenols with Phosphorus Pentachloride.

Calixarenes consist to *O,O*-substituted phenols and/or bridged aromatic polyols. Such phenols (**1**, **4**, **7**; see figure 1) react with  $\text{PCl}_5$  to give chlorophosphonium salts (**2**, **8**) or trichlorophosphoranes (**5**). The hydrolysis of these derivatives forms the acyclic phosphate **3**, the cyclic phosphate **6** or the bicyclic phosphate **9** [2].

Figure 1

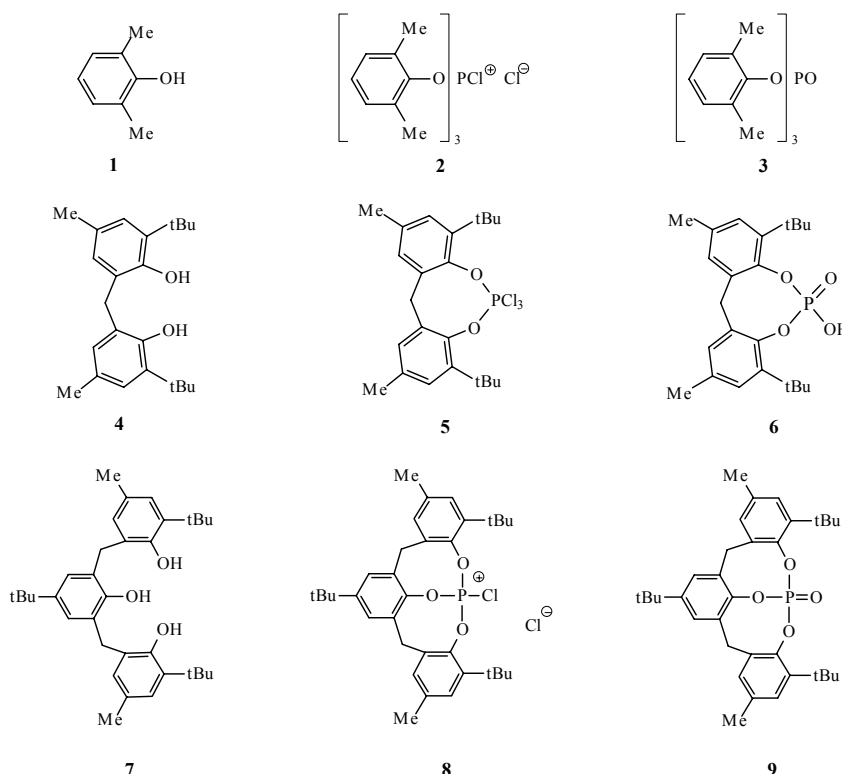

#### II. 1,2,3-Bridged Calixarene Phosphates or the Reaction of Calixarenes with Phosphorus Pentachloride.

The *p-tert*-butylcalix[n]arenes ( $n = 4, 6, 8, 9$ ) react in the same manner as the bridged aromatic polyols (see figure 2).

In all cases the first step is the reaction of three hydroxyl groups with  $\text{PCl}_5$  and the formation of an 1,2,3-bridged chlorophosphonium unit. And the second step is the reaction of the last hydroxy groups with  $\text{PCl}_5$  and the formation of chlorophosphorane units (**10a**, **10c**) or bicyclic chlorophosphonium units (**10b**, **10d**) [3].

The hydrolysis of these salts leads to 1,2,3-bridged calixarene diphosphates (**11a**, **11b**) or triphosphates (**11c**, **11d**) (see figure 3).

In the case of **11c** two conformers exist (possible structures are the acids **A** and **B**) (see figure 4). The cyclic acid **C** was isolated by alkylation of **11c** and sensitive dealkylation with  $\text{Me}_3\text{SiBr}$ .

The *p-tert*-butylthioalix[4]arene reacts with  $\text{PCl}_5$  to give the derivative **12** with two hexacoordinated phosphorus atoms ( $^{31}\text{P}$ -NMR: -133 ppm). The hydrolysis of **12** leads to the thioalixarene bis(chlorophosphate) **13** (see figure 5) [4].

The spherand-type calixarene **14** reacts in the same manner as the corresponding calix[6]arene derivative to form the phosphonium salt **15**. It hydrolyzes to the *anti* diphosphate **16** (see figure 6).

#### III. 1,2-Bridged Calixarene Phosphates or the Reaction of Calixarenes with Phosphorus Oxychloride.

*p-tert*-Butylcalix[4]arene reacts with  $\text{POCl}_3$  to give partial and full phosphorylated 1,2-bridged calixarene chlorophosphates (**17a** and **18a**) [5, 6]. The phosphorylation with chlorophosphates gives the corresponding alkyl phosphates (**17b** and **18b**) (see figure 7) [7].

Whereas *p-tert*-butylcalix[6]arene with  $\text{POCl}_3$  forms an 1,2,3-bridged phosphate (**11b**), but *p-tert*-butylcalix[8]arene gives an 1,2-bridged tetrakis(chlorophosphate) (**19a**). The hydrolysis leads to the 1,2-bridged calixarene tetraphosphate **19b** [8].

Figure 2

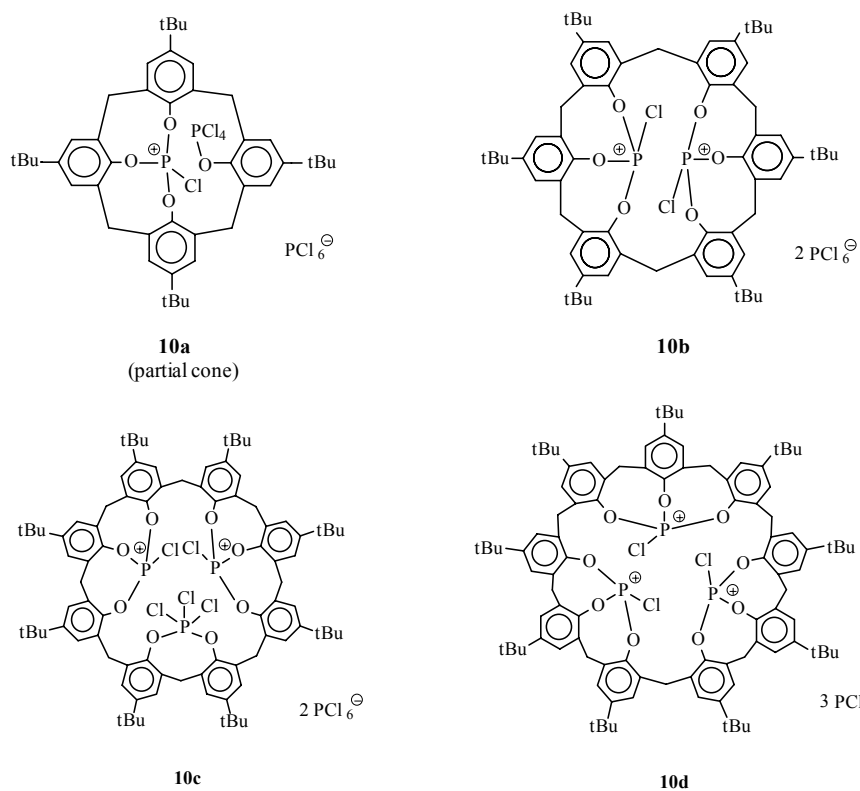
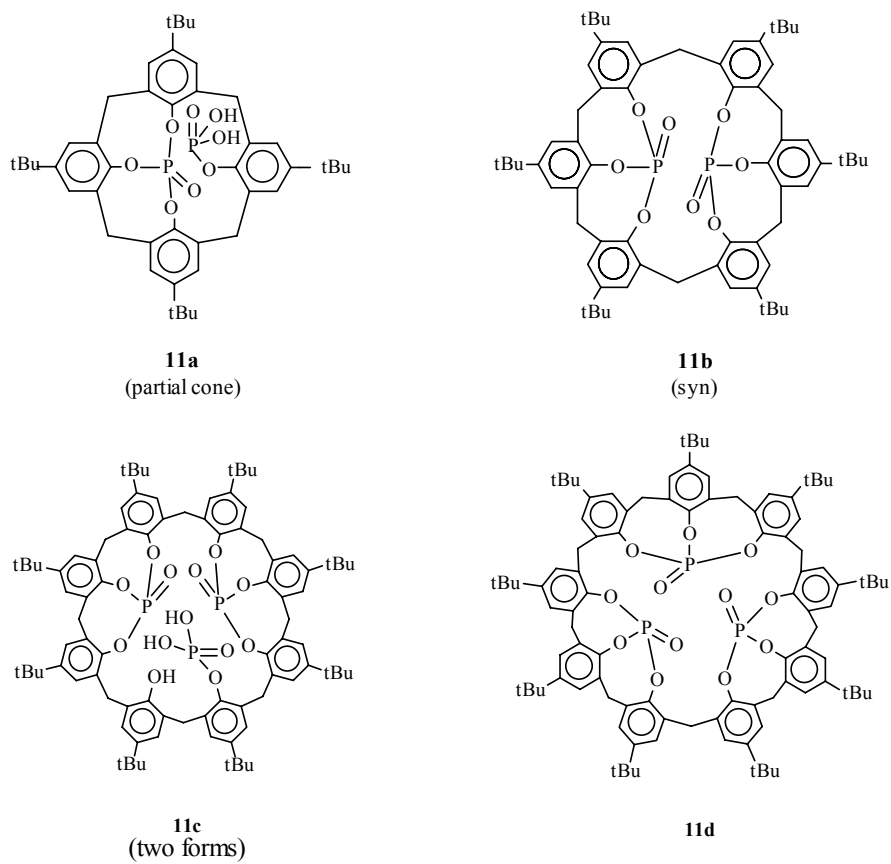

Figure 3



**Figure 4****Figure 5****Figure 6**

Figure 7



The reaction of the deformed derivative **14** with  $\text{POCl}_3$  forms the stable bis(chlorophosphate) **20**, which contains in the molecule a 7-membered and an 8-membered cyclic chlorophosphate group (see figure 7).

## References

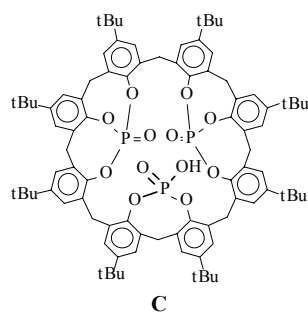
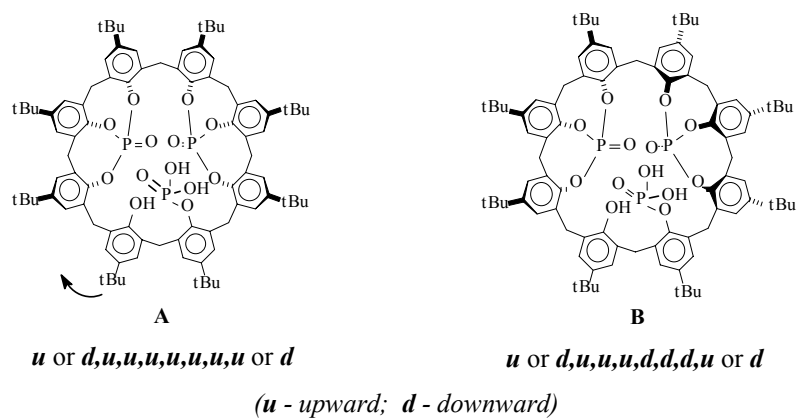
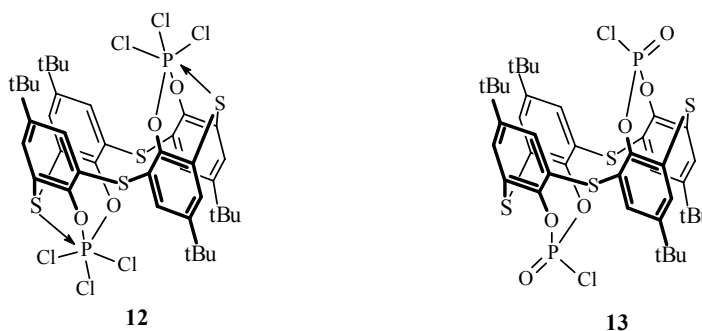
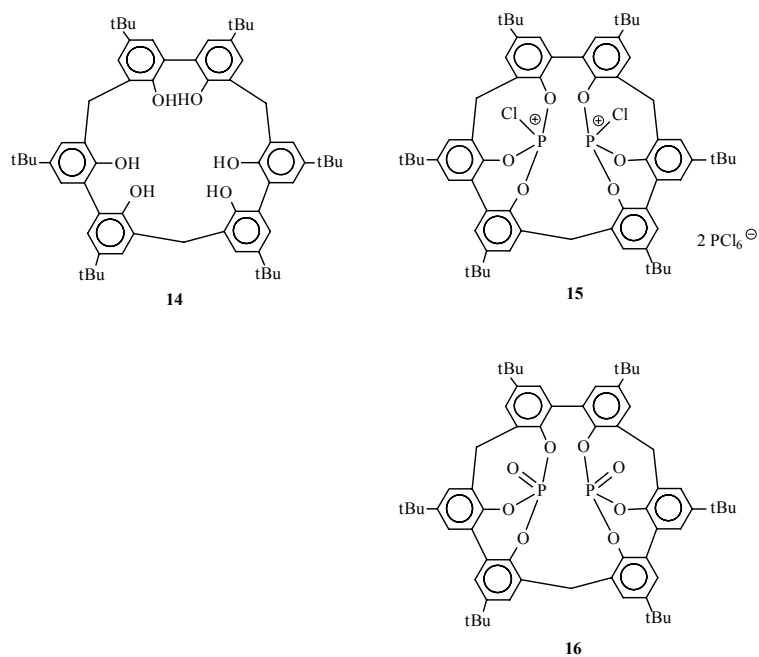
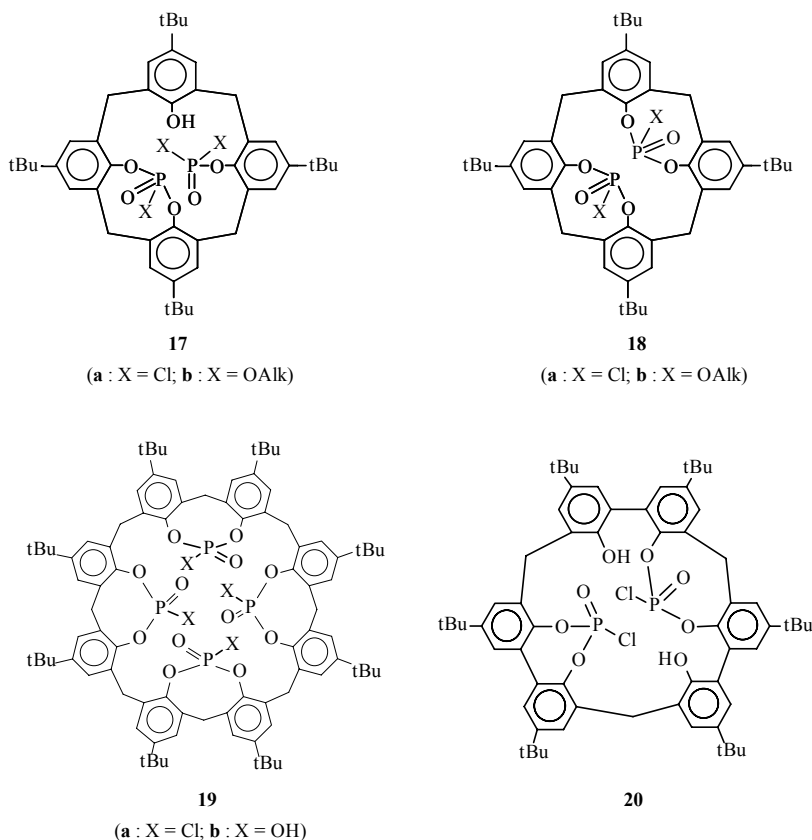
- [1] Review: J. Gloede. *Phosphorus, Sulfur, and Silicon*. **1997**. 131. 97.
- [2] J. Gloede, I. Keitel. *Phosphorus, Sulfur, and Silicon*. **1998**. 132. 9.
- [3] J. Gloede, B. Costisella, M. Ramm, R. Bienert. *Phosphorus, Sulfur, and Silicon*. **84 (1993)** 217. J. Gloede, I. Keitel. *Phosphorus, Sulfur, and Silicon*. **1995**. 104. 103; J. Gloede. 5<sup>th</sup> International Conference on Calixarene Chemistry. Perth, 19-23.9. **1999**. *Abstract*, P-29.
- [4] J. Gloede, S. Ozegowski, D. Weber, W. D. Habicher. *Phosphorus, Sulfur, and Silicon*, in preparation.
- [5] O. Aleksiuik, F. Grynszpan, S.E. Biali. *J. Incl. Phenom*. **1994**. 19. 237.
- [6] J. Gloede, I. Keitel, B. Costisella, A. Kunath, M. Schneider. *Phosphorus, Sulfur, and Silicon*. **1996**. 117. 67.
- [7] L.T. Bryne, J.M. Harrowfield, D.C.R. Hockless, B. J. Peachey, W. Skelton, A. H. White. *Aust.J.Chem.* **1993**. 46. 1673; J.W. Harrowfield, M. Mocerino, B.J. Peachey, B.W. Skelton, A.H. White. *J.Chem.Soc., Dalton Trans.* **1996**. 1687.
- [8] J. Gloede. 5<sup>th</sup> International Conference on Calixarene Chemistry, Perth. 19-23.9. **1999**. *Abstract*, P-30.